

HDD/tunnelling

*Tools for
true heroes!*



MADE IN GERMANY

BETEK

Progress!

In use worldwide: BETEK tungsten carbide tools



1 - Road milling



2 - Surface mining



3 - Stabilising



4 - Recycling



5 - Foundation drilling



6 - Crushing and mixing



7 - Horizontal directional drilling HDD



8 - Mining



9 - Trenching



10 - Tunnelling



11 - Hydraulic milling cutters



12 - Forest mulching



13 - Agriculture



14 - Rail track construction



15 - TungStuds

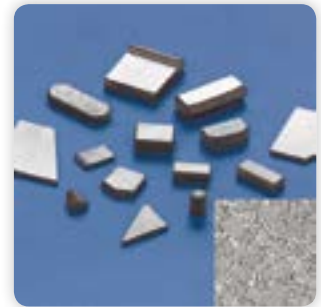

16 - Abrasive wear protection

Use innovative tool systems from BETEK – and you'll make good progress with above-average daily productivity! The contours of BETEK tools and the grade of tungsten carbide used are always tailored to the job at hand. This ensures a long service life and minimal tool changes.

Progress well with wear-resistant grades of tungsten carbide

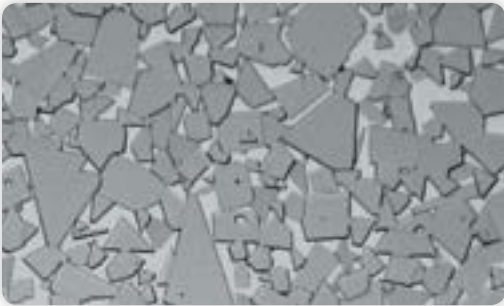

Cross-section through grade B20G tungsten carbide, as used, for example, for tunnelling

Tungsten carbide and steel – firmly bonded for extreme demands

Steel and carbide are two materials with totally different expansion coefficients when subjected to heat. Nevertheless, it is of steel and tungsten carbide that our tools are made, with tungsten carbide for the wear-resistant tip, and steel for the tool shank. Since tools reach high temperatures during use, extreme tensile stresses are generated. These stresses are absorbed by a special brazing material that joins the tungsten carbide tip to the steel section.

We have developed our own methods and systems for this brazing process, which is carried out on fully automated machines with the process covered in an inert protective gas. Manufacturing parameters are fully monitored and documented to ensure consistent quality. Afterwards, brazing shear strengths are checked to ensure that our “Masters of the construction site” lose no time due to broken tools!



Monitored manufacturing on the fully automated soldering machine



The soldering process to permanently bond tungsten carbide and steel

How our high-tech tools are made

- Cost-effective client solutions based on flexible structures
- Tailored, fast response to client requirements

Customer service

- Speedy creation of samples and prototypes
- Competitive prices thanks to close collaboration with all areas of production

Development & design

- Raw materials of high purity used for great strength
- Consistently high, pore-free tungsten carbide quality produced through an exact process resulting from years of experience and know-how

Tungsten carbide manufacturing

Production equipment and processes specially developed to the utmost degree of perfection by experts in combining tungsten carbide and steel

The soldering side of production

Able to compete on the world market by virtue of a high degree of automation and flexible manufacturing plants

Automation

Permanent checking of quality in accordance with DIN ISO 9001:2000 and DIN EN ISO 14001 along the entire production chain all the way to the construction site

Quality assurance

User training sessions at Betek or on the construction site itself to ensure long-term economic success and client satisfaction

Training

Able to react quickly thanks to:

- The use of cutting edge IT and optimum logistics links
- Standard products kept in store

Logistics

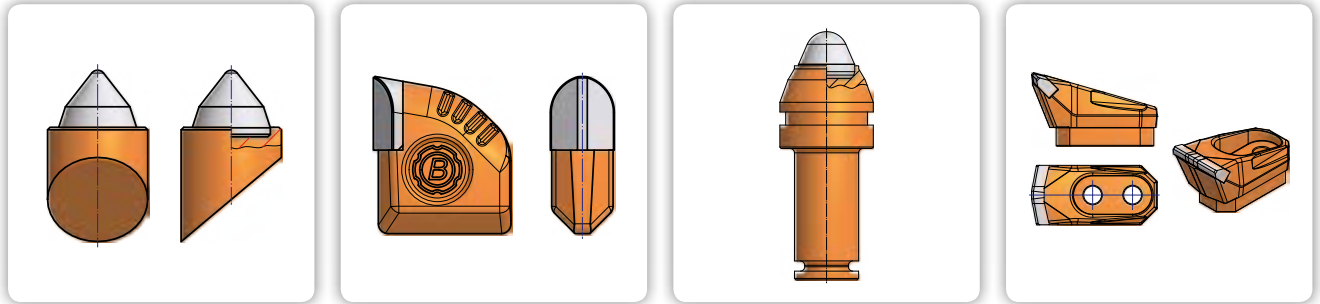

Tool range

Page

Horizontal Directional Drilling

6 – 13

Tricone Bits

8

Weld-on teeth

9 – 12

Round shank cutter bits

13 – 17

Tunnelling

18 – 22

Scraper blades

19 – 21

Reamer

22

Wear protection

23

Below the pictures of tools on the following pages you will find the following information:

→ **Art-No**

→ Description



← Packaging unit

Dimensions: mm / inches

Welding instructions see:

www.betek.de/en/productprogramme/mining-tunneling-userinfo.html



SUPPORT:

Germany: info@betek.de

Tel.: +49 (0) 74 22 / 5 65-591

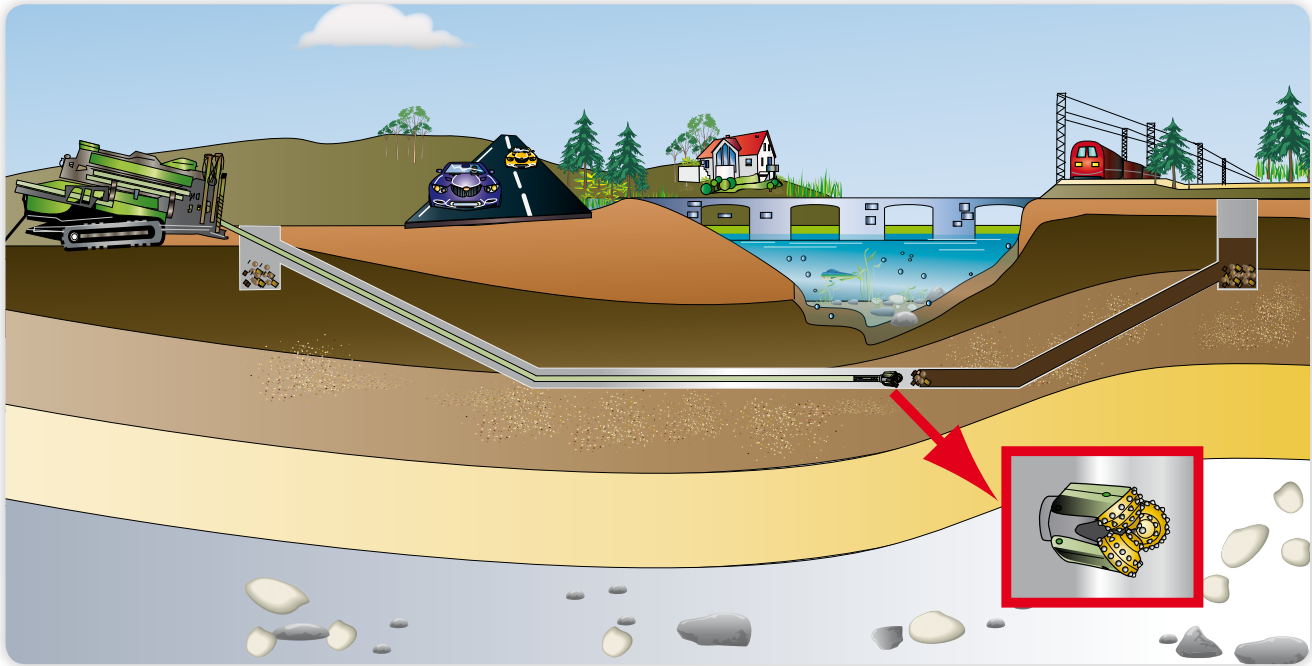

HDD – Horizontal Directional Drilling

HDD (horizontal directional drilling) originates from the USA. It was introduced in the seventies as a deep drilling technique and has been developed constantly since that time.

Horizontal drilling is used primarily to cross below fixed surfaces (e.g. roads, railroads, airport runways etc.) and waterways in order to construct pipelines or cable lines without digging trenches.

The application areas for this technique are gaining greater importance every year. Examples of these include pipeline construction for crude oil, gas, refinery products, water, effluent and community heating networks, as well as extending underground electricity supply and data lines.

Horizontal drilling is done in three steps in general:

1. Pilot bore hole using a pilot drill (in hard rock with a tricone bit)
2. Widening process appropriate to soil conditions using a hole opener or reamer
3. Process to pull in the pipeline using a reamer

Using tungsten carbide tools on a HDD machine:

Tools tipped with tungsten carbide are not widely used in geological conditions where the rock is very soft. For that tools with hardened steel or hard facing are used.

If the rock is harder, tungsten carbide wear parts are used on the drilling tools. These may be tungsten carbide pins soldered or press-fitted onto the pilot drills, welded-on teeth and round shank bits on reamers and hole openers and/or rock-drilling heads for hard rock (tricone bits).



BETEK Tricone Bit, Typ BTB09



Reamer with pipe-pulling mechanism



Reamer



Fly Cutter

Betek BTB09 tricone bits technical product information

Technical data

Borehole diameter:	5 3/4" (146 mm)	Max. feed force:	30,000 N
Connection thread:	2-7/8" -5 API regular taper	Weight:	12.23 kg

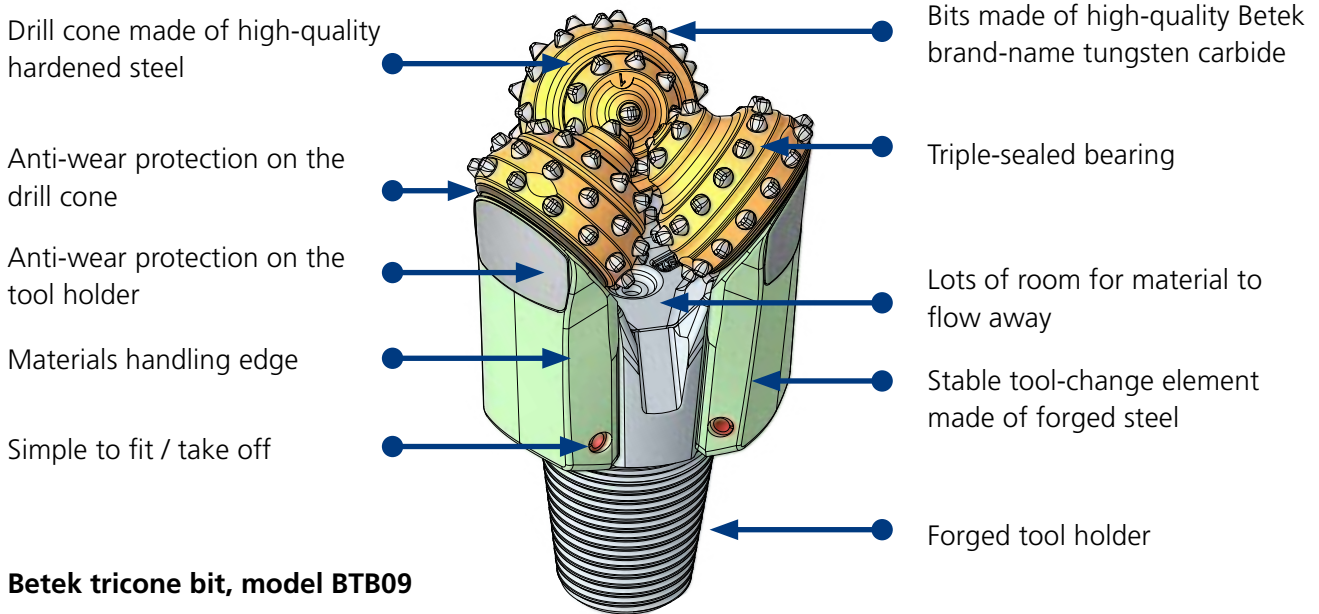

Benefits

- Complete tool-change system can be replaced (patent pending)
- Individual components (drill bits) can be replaced (patent pending)
- Runs with minimal vibration thanks to optimised shape of tool-changer arms
- Larger free cut means reduced wear on the steering head
- Less wear on the tool-changer arms thanks to geometrically optimum shape of the components (patent pending)
- Big cost benefit from reusable components
- Excellent value for money

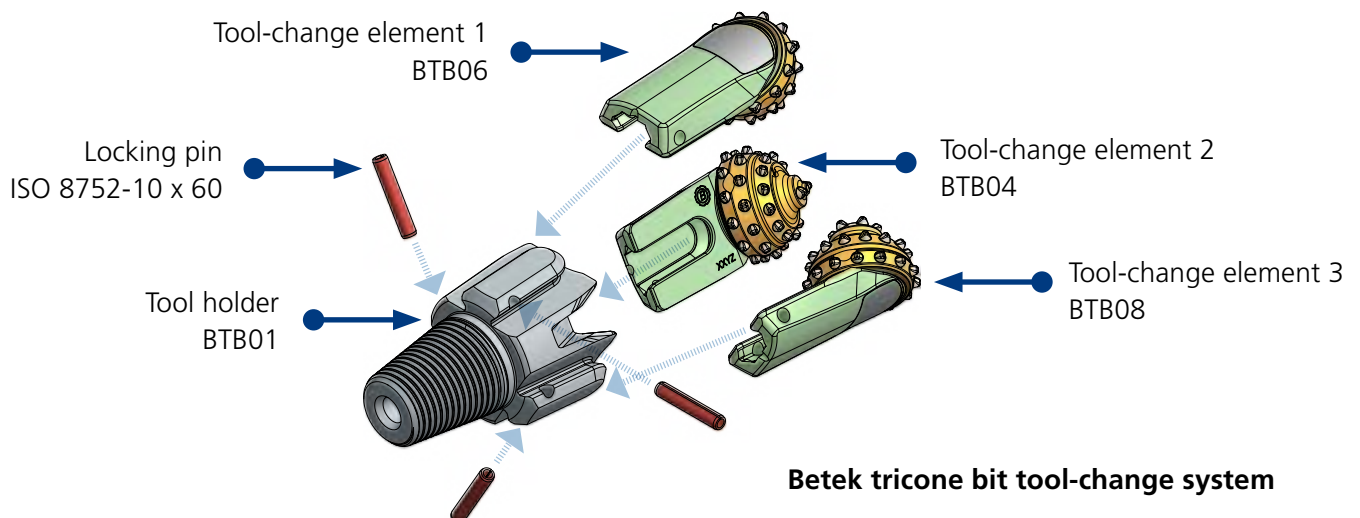

HDD Horizontal Directional Drilling Weld-on Teeth

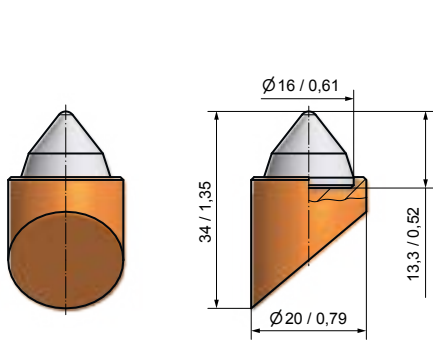

BFZ158
BFZ3 250

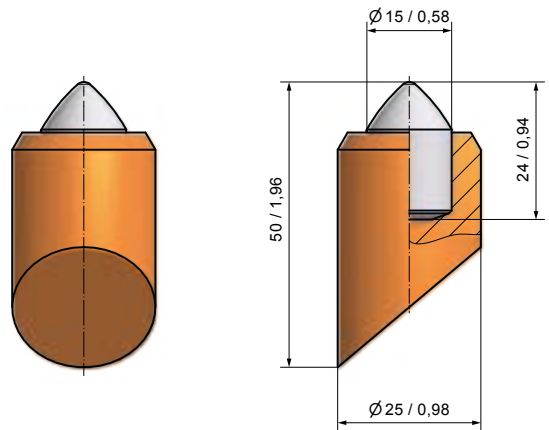

BFZ207
BFZ1 100

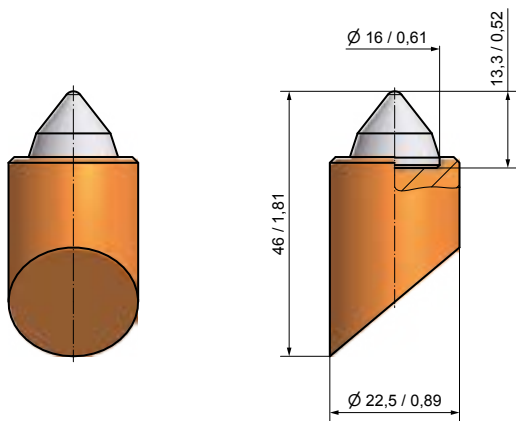

BFZ283
BFZ3/46-Z 150



Illustration: HDD reamer with BFZ283

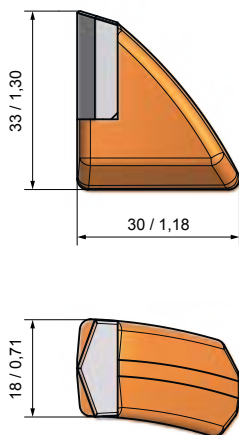

BFZ107
BFZ18/R 200

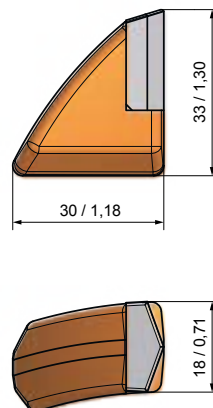
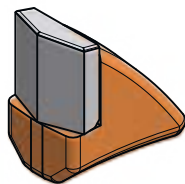

BFZ144
BFZ18/L 200

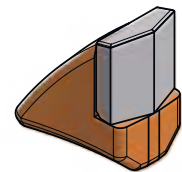

HDD Horizontal Directional Drilling Weld-on Teeth

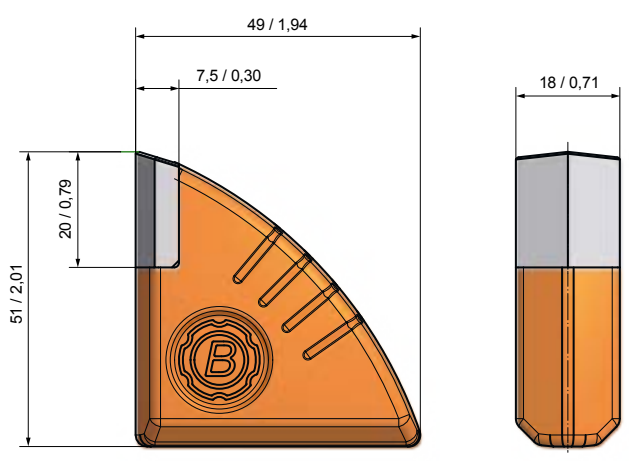

BFZ87
BFZ 18/2

50

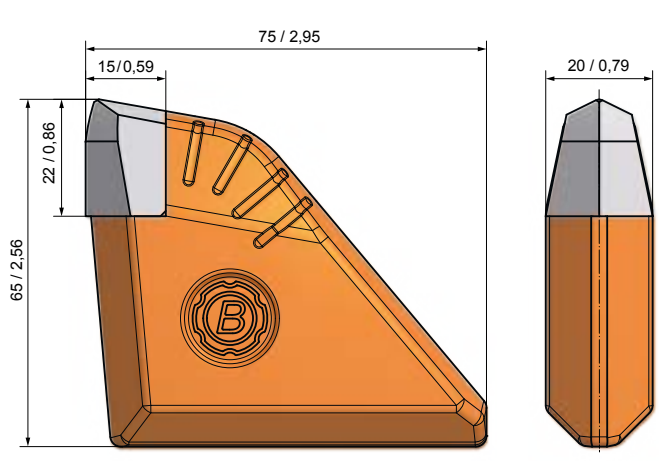

BFZ319
BFZ 75x65x20

25

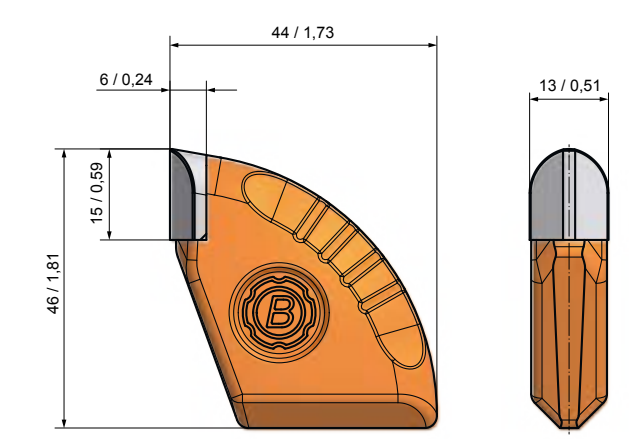

BFZ318
BFZ 46x44x13

100

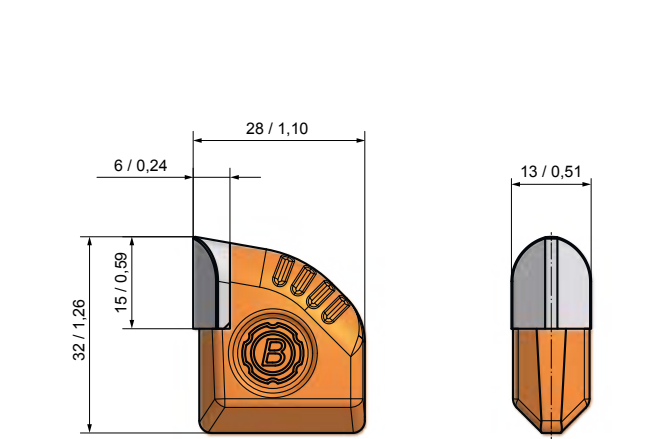

BFZ321
BFZ 32x27x13

100

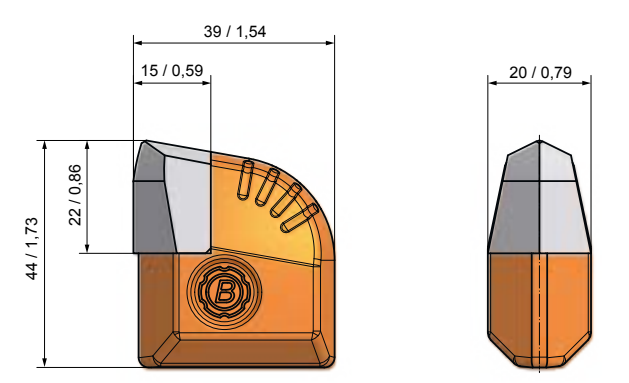

BFZ320
BFZ 44x39x22

50



HDD Horizontal Directional Drilling Weld-on Teeth

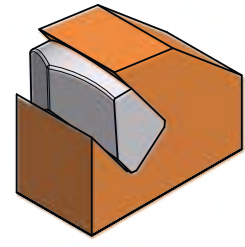
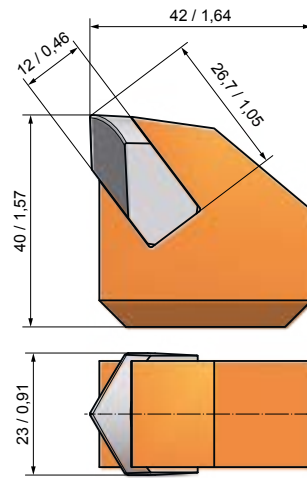
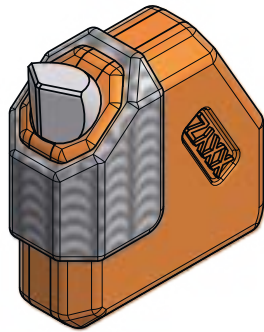
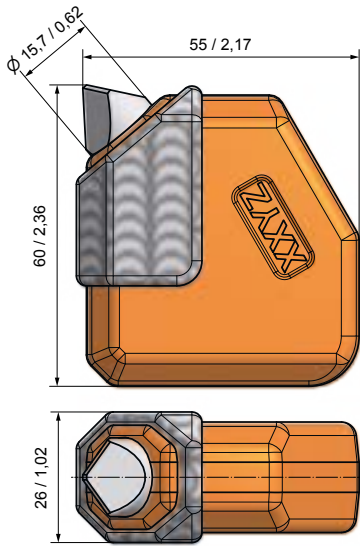

BFZ257
BFZ 60x55x22 

BFZ260
BFZ 42x40x23 

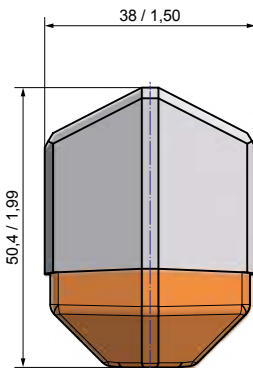
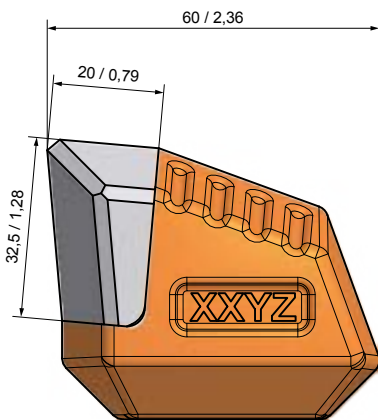

BFZ326
BFZ 38/M 



HDD Horizontal Directional Drilling Weld-on Teeth

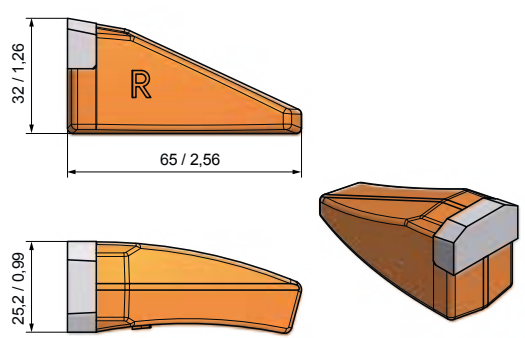

BFZ25R
BFZ25-R 50

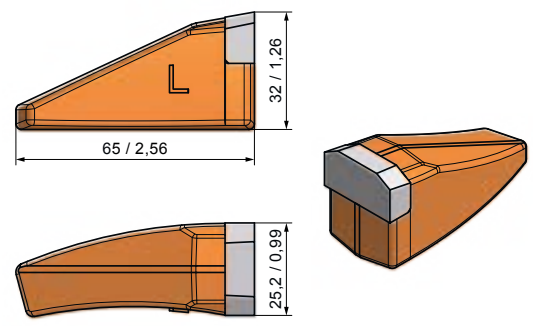

BFZ25L
BFZ25-L 50

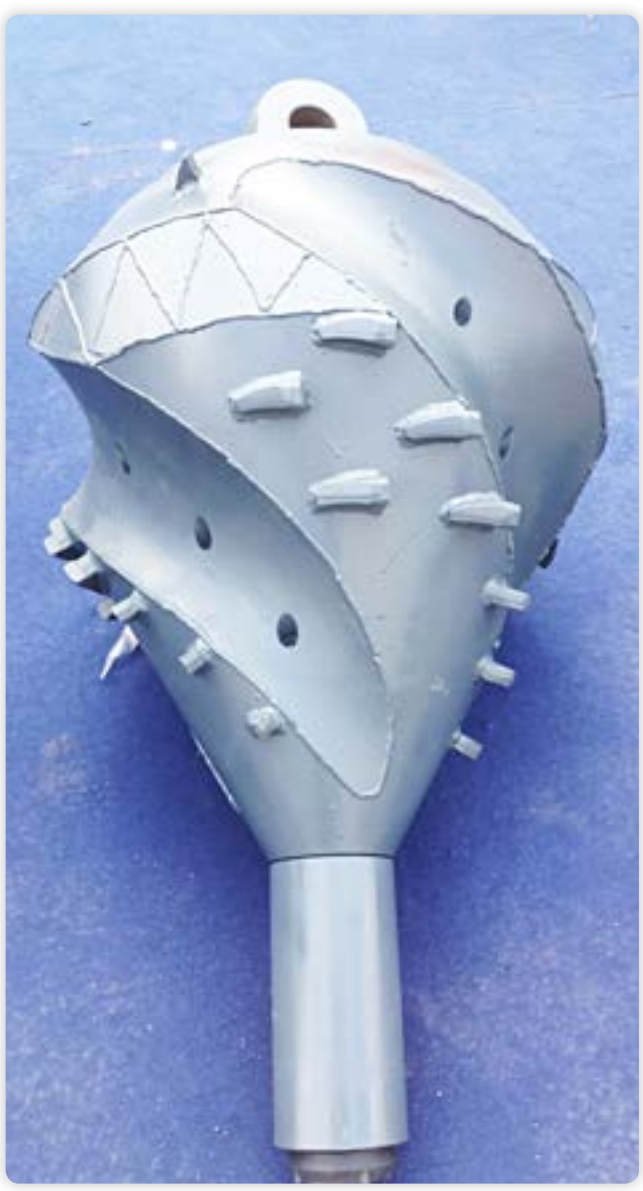
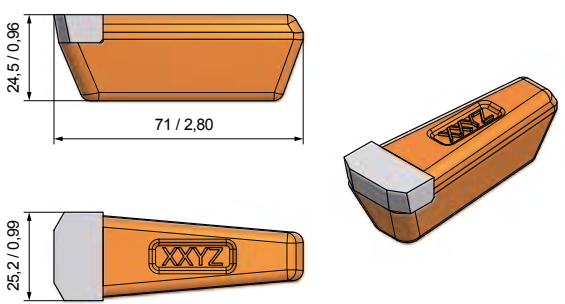

Illustration: HDD reamer with BFZ25L



BFZ96
BFZ71x25 50

HDD Horizontal Directional Drilling

Round shank cutter bit

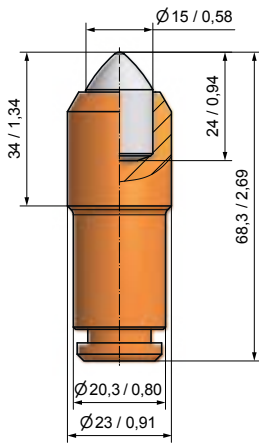

BSR187
BG20X-15.2334

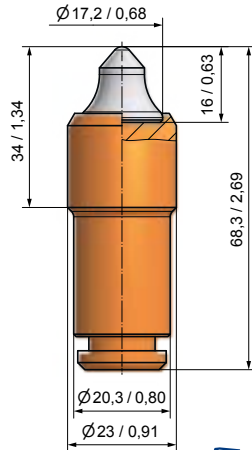

BSR186
BG20X-62.2334

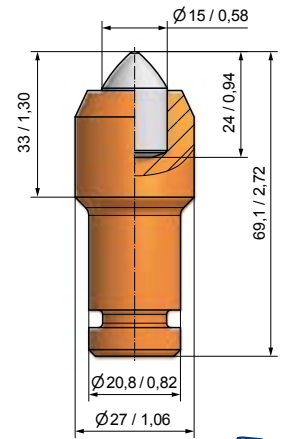

BSR93
BG21X-15.2733

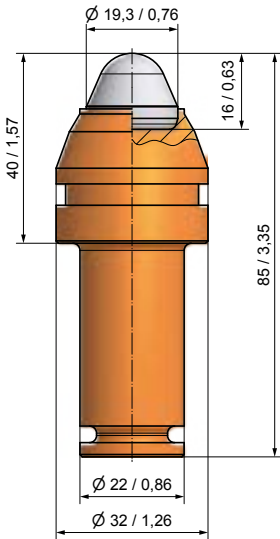

BC80
BG22X-19.3240

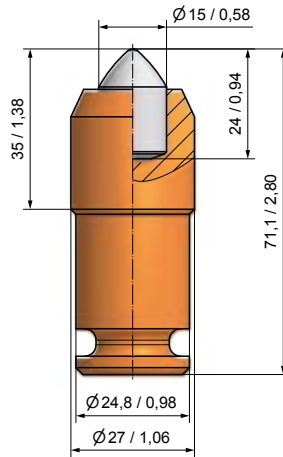

BSR115
BG25X-15.2735

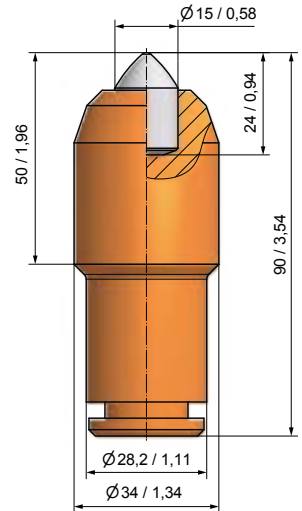

BSR110
BG28F-15.3450



Round shank cutter bit Shank system Ø 11,3 mm/0,44"

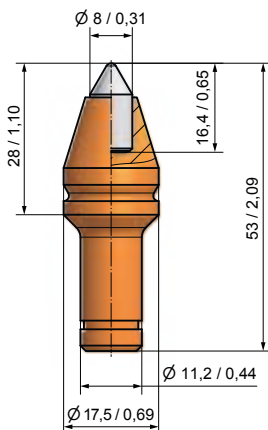

BM11
BM8-11.3

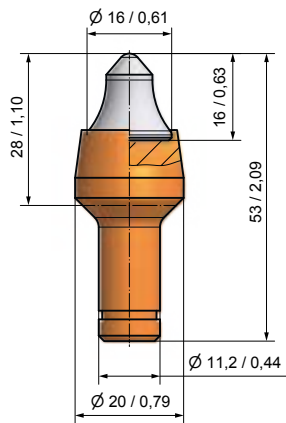

BM10
BM4-11.3

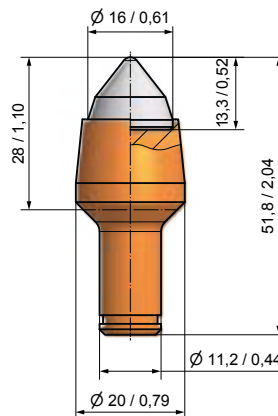

BM46
BM3-11.3

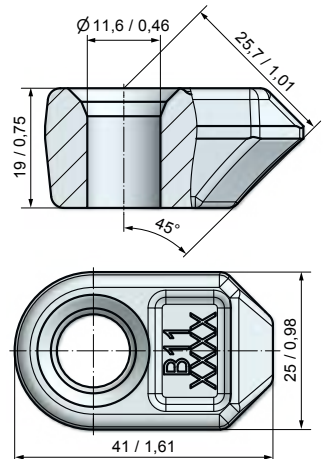

BHR03
B11

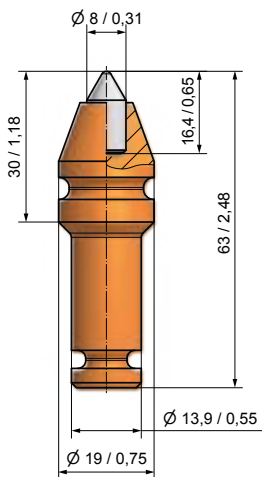

Shank system \varnothing 14 mm/0,55" – Lock ring SR90

Sicherungsring SR90

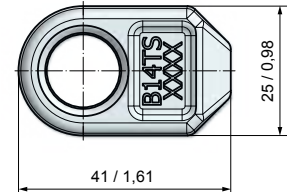
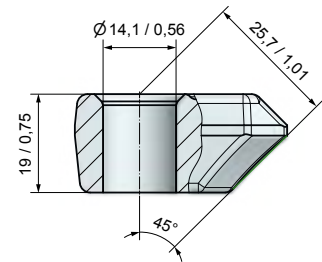
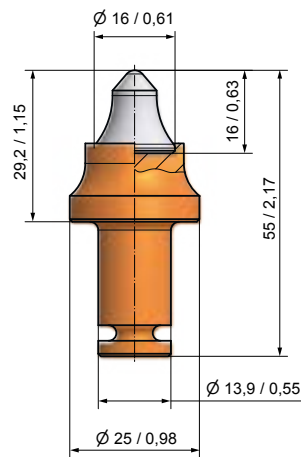
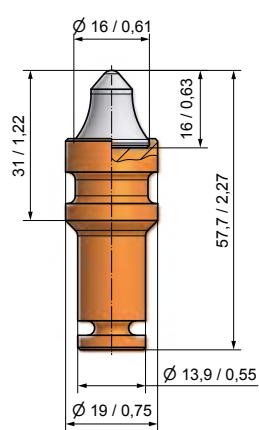
BM84
BM8-14

200

BM44
BM4-14

200

BM76
BM4-14/TS

200

BHR171
B14-TS

200

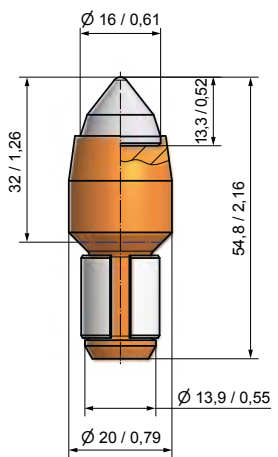
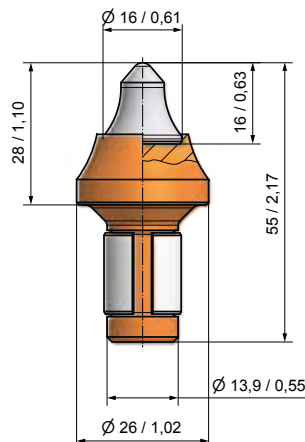
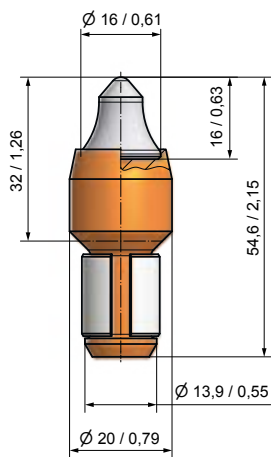
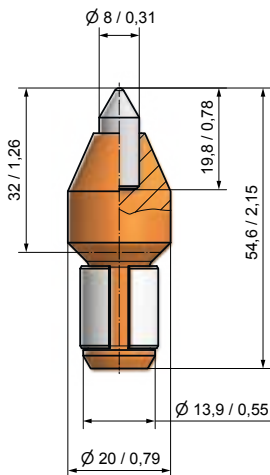
Shank system \varnothing 14 mm/0,55" – Clamping sleeveBM56
BM8-14/2

200

BM55
BM4-14/2

200

BM82
BM4-14/3

200

BM60
BM3-14/H

200

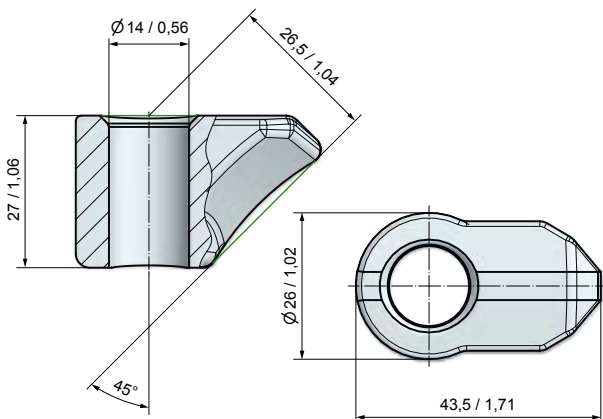
BHR109
B14

150

BZ44
Bit extractor

Shank system Ø 19,4 mm/0,76"

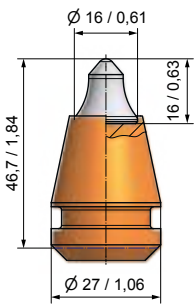

BSH204
B4

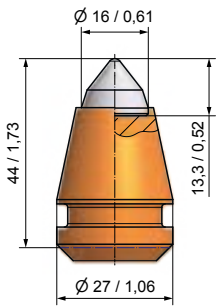

BSH09
B3

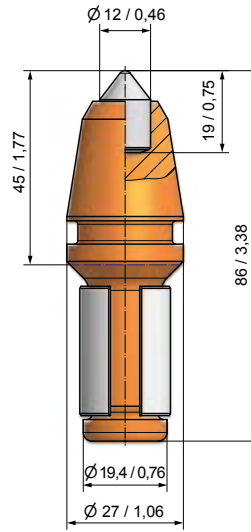

BSH05
B1HDK12

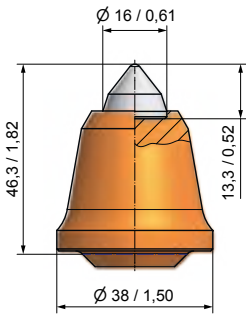

BSH211
B3/38

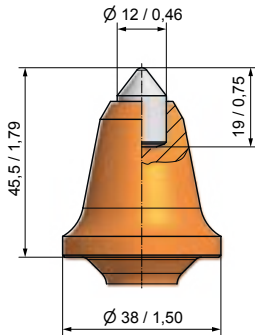

BSH210
B1-12/38

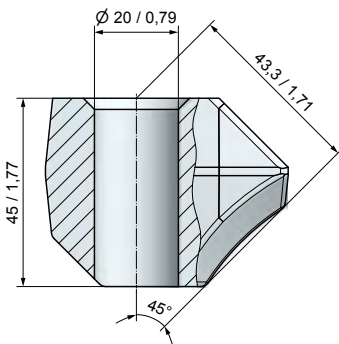

BHR05
B10

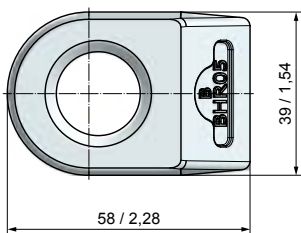

BZ42
Bit puller

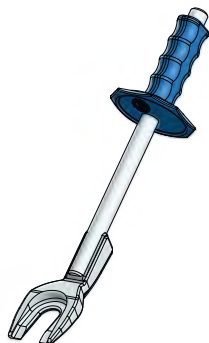

BZ43
Bit extractor



BZ38
Wedge puller

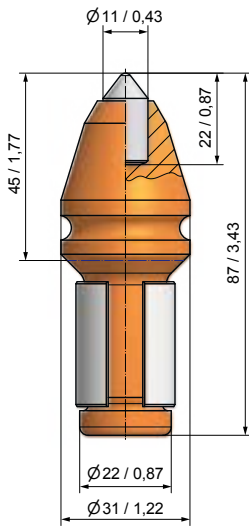

Shank system $\varnothing 22 \text{ mm}/0,87''$ **BC05**

50

B1HDK11/22

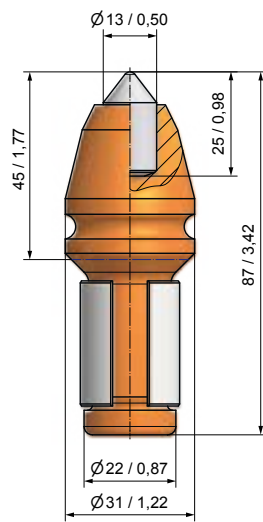
**BC06**

50

B1HDK13/22

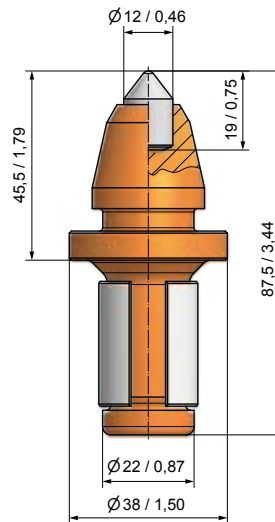
**BC60**

40

B1-12/22

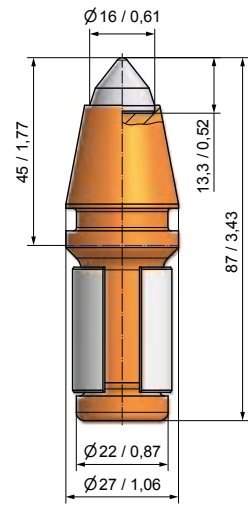
**BC49**

50

B3/22

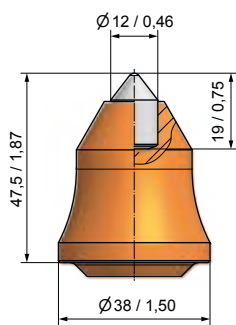
**BC64**

40

B1-12/22-B

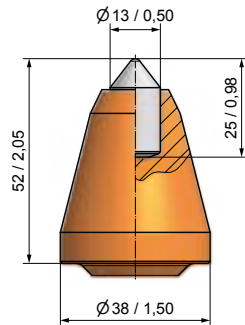
**BC14**

40

B1HDS38/13/22

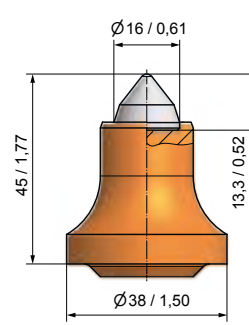
**BC41**

50

B3S/22

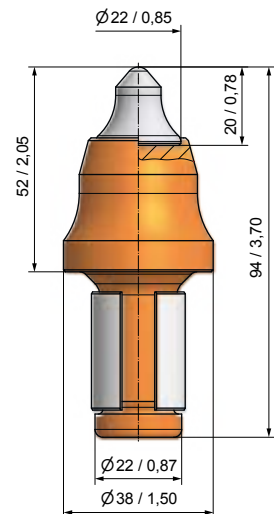
**BC03**

40

B8S/22

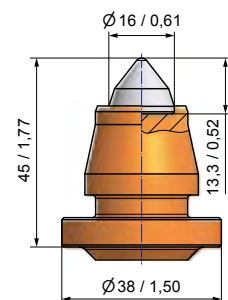
**BC81**

50

BG22H-60.3845

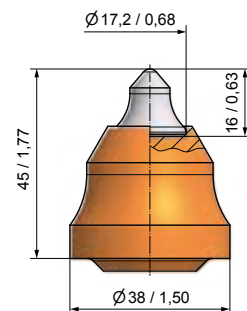
**BC04**

50

B5S/22

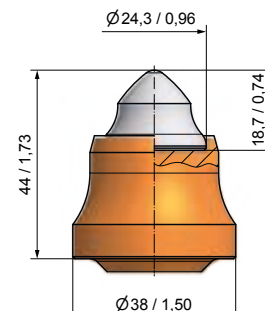
**BC43**

40

B9/22

Shank system Ø 22 mm/0,87"

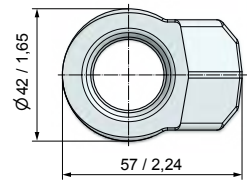
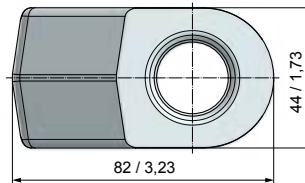
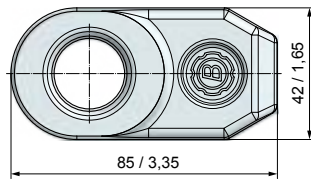
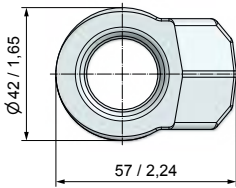
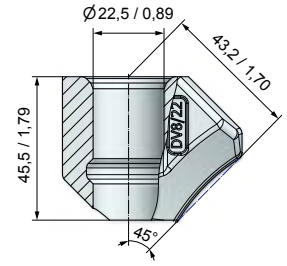
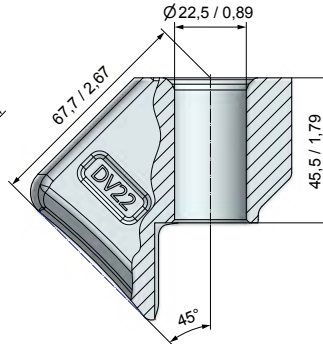
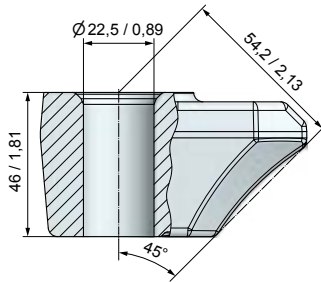
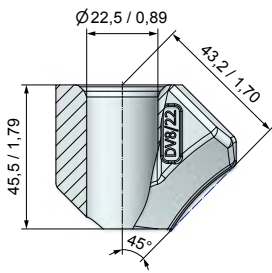

BHR27
DV8/22



BHR120
B22S



BHR30
DV22



BHR176
DV8/22-K



BZ42
Bit puller



BZ43
Bit extractor



BZ38
Wedge puller



Tunnelling

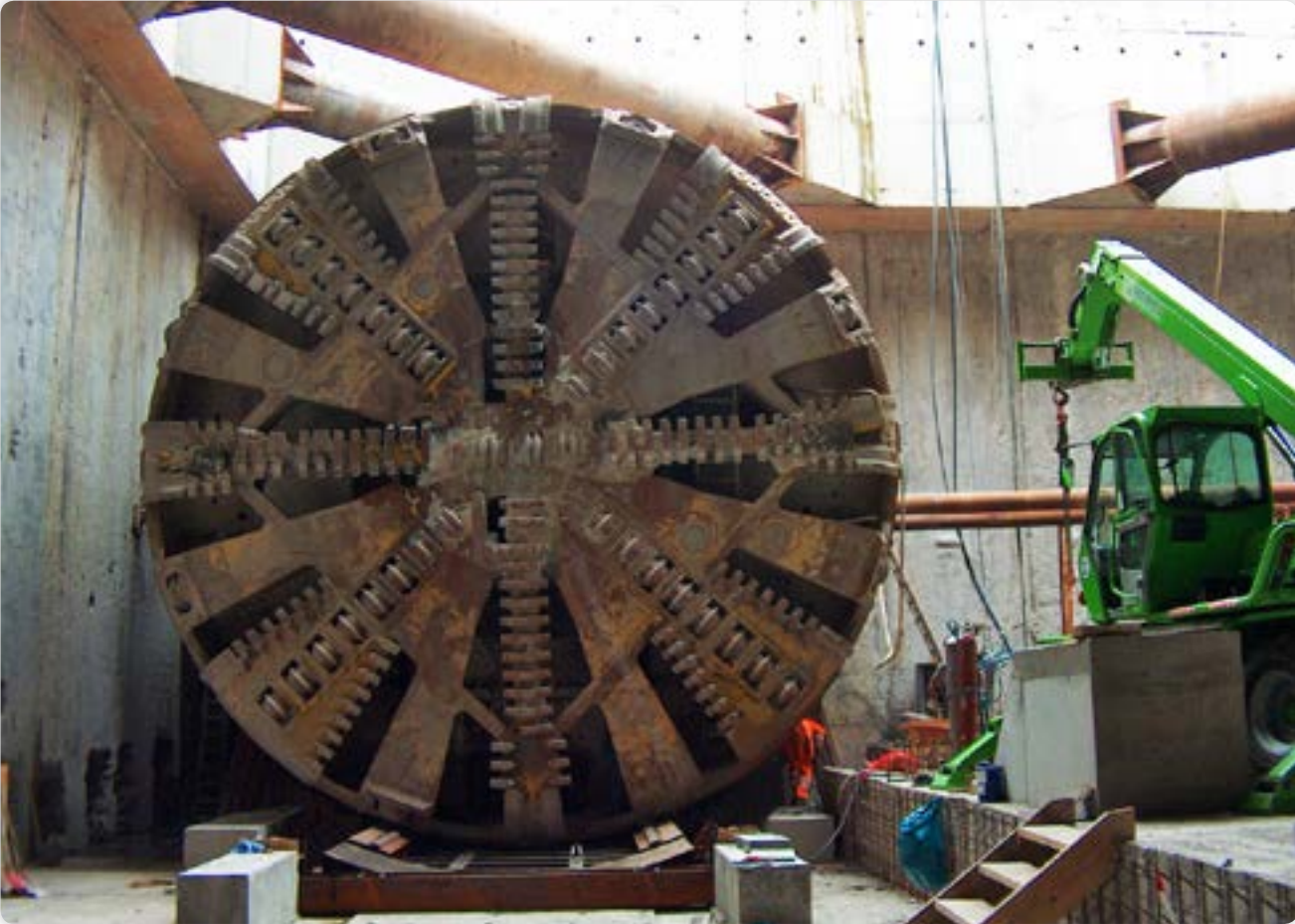

Microtunnelling – Scraper blades

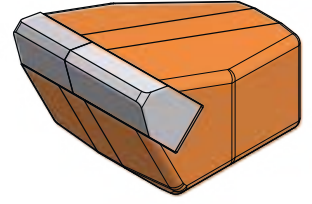
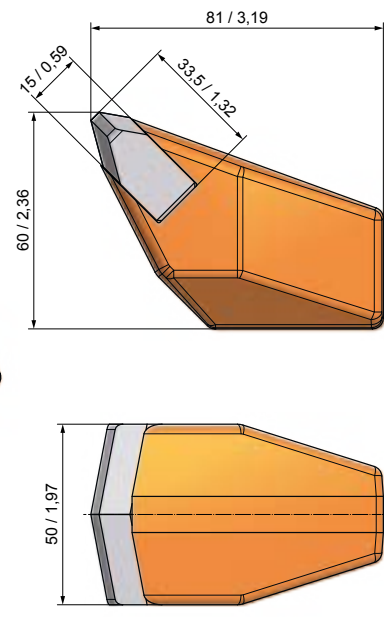
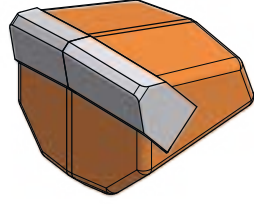
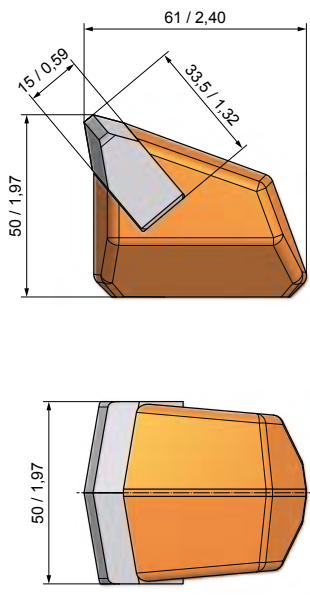

BFZ51
BFZ51

20

BFM08
BFM112x50/S

15

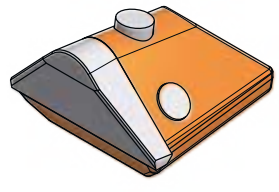
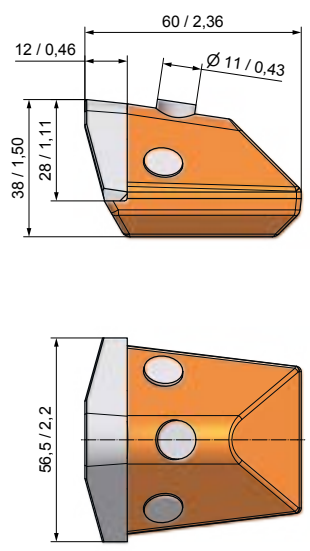

BFZ163
BFZ56

20



Microtunnelling – Scraper blades

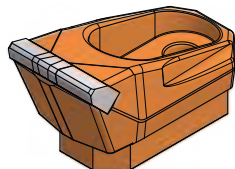
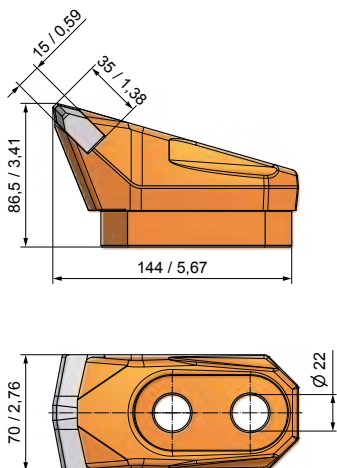

BFM81
BFM144x70/M20
M20 thread

BFM83
BFM144x70/M24
M24 thread

BFM07
BFM144x70

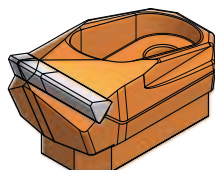
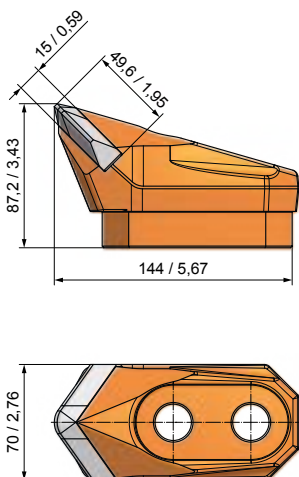

BFM16
BFM144x86x70



Illustration: Scraper blades BFM70 on a Microtunnelling machine

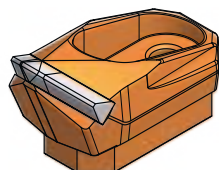
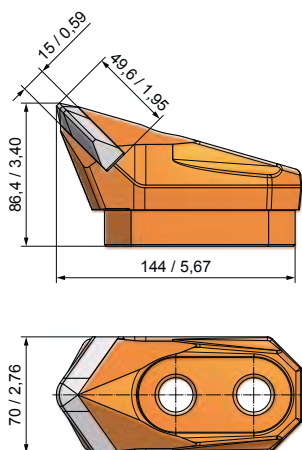

BFM70
BFM144x86x70/1

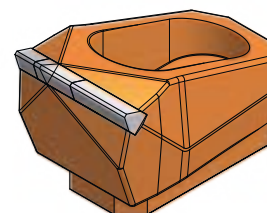
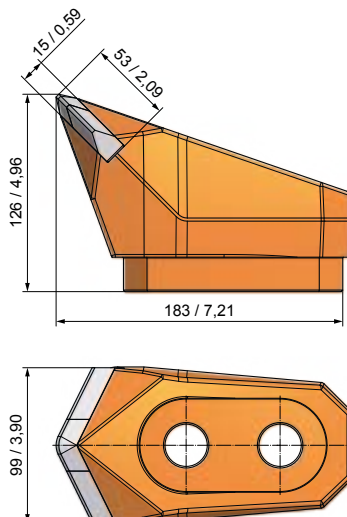

BFM71
BFM183x126x100



Scraper blades for TBM

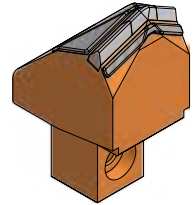
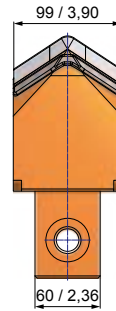
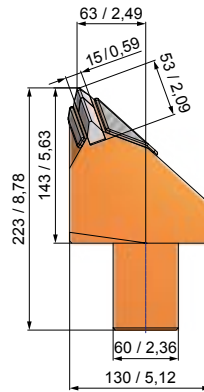
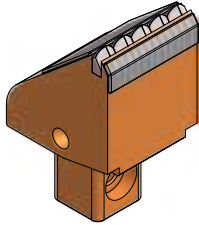
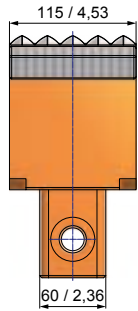
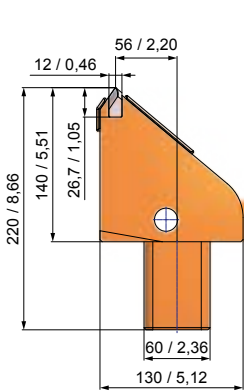

BFZ280
BFZ220x115



BFZ275
BFZ222,5x100

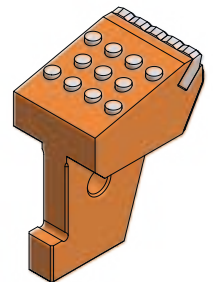
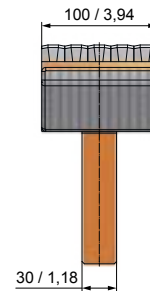
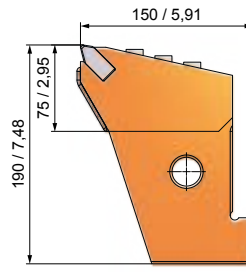
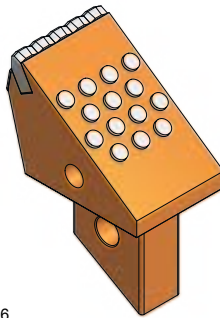
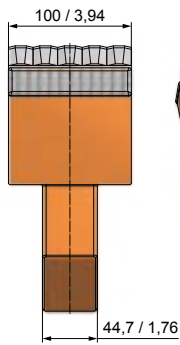
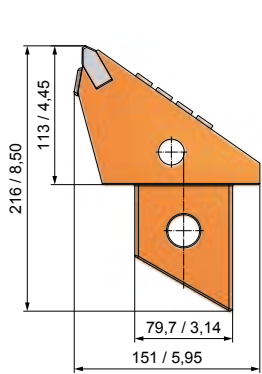

BFZ303
BFZ216x151x100



BFM77
BFZ168x132/B100

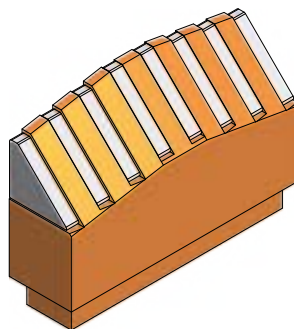
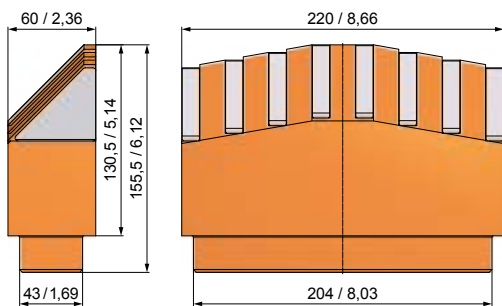

BFM85
BFM220x156x60

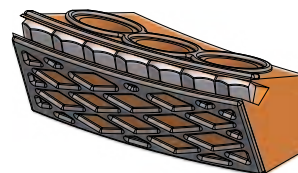
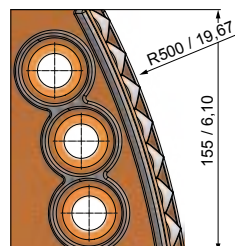
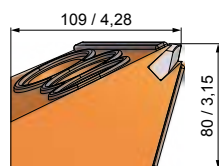
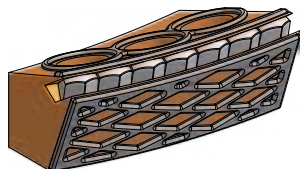
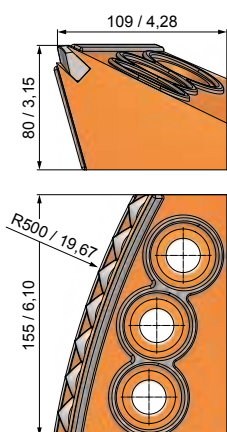

Reamer

**BRS13**

BRS155x110x80/R

1

BRS14

BRS155x110x80/L

1

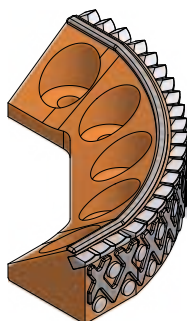
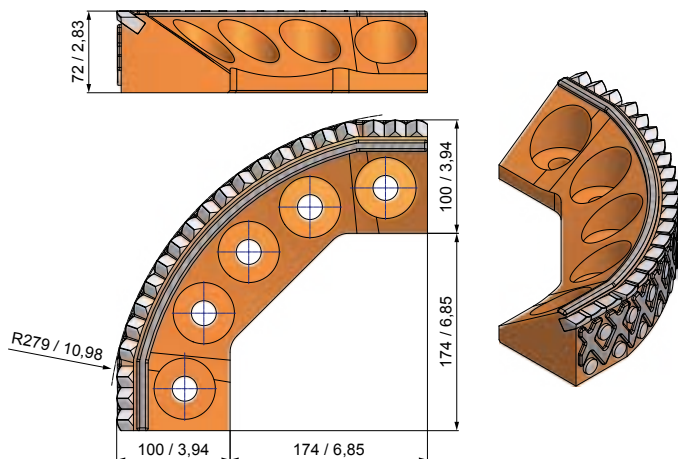
**BRS15**

BRS274x274x80

1

BETEK TungStuds with tungsten carbide core: Effective protection against wear for metal surfaces

BETEK TungStuds are on the front line when material is produced or processed. The TungStuds which are equipped with a tungsten carbide core are the first to come into contact with the material to be conveyed and are subjected to extreme abrasion. In addition to the wear protection through the TungStuds, the bound material to be conveyed is used as a material cushion. This means the direct abrasion of the metal surface due to the movement of materials is reduced.

Instead of expensive spare parts which may be required due to worn-down metal surfaces, it is only necessary to replace the TungStuds. When using BETEK TungStuds also the maintenance outlay is reduced. Because of their tungsten carbide core they can resist to the most extreme conditions.



Further information: www.betek.de/en/productprogramme/tungstuds

* Height subsequent to welding on

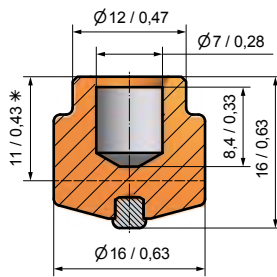

BTS01

BTSD16/16

150

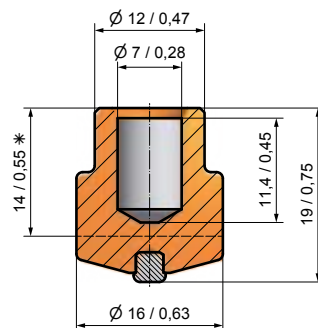

BTS02

BTSD16/19

150

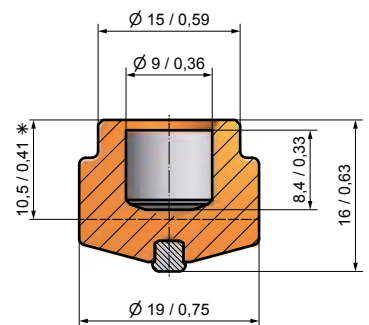

BTS03

BTSD19/16

150

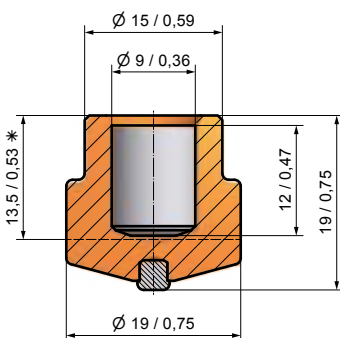

BTS04

BTSD19/19

150

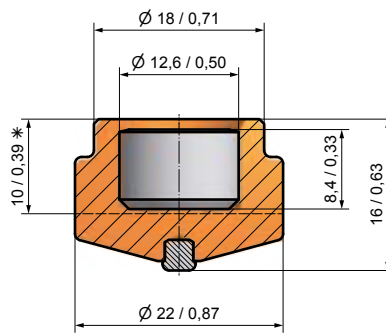

BTS05

BTSD22/16

100

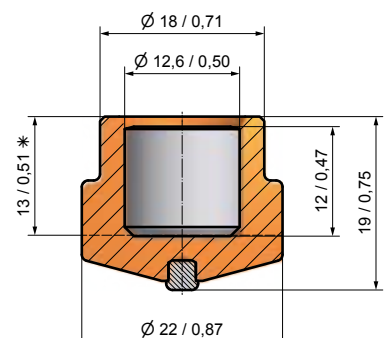

BTS06

BTSD22/19

100

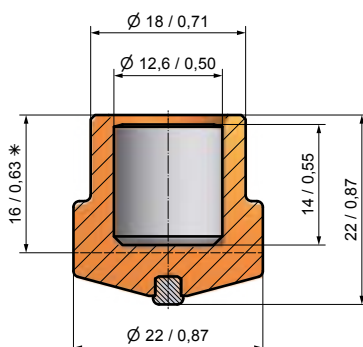

BTS07

BTSD22/22

100

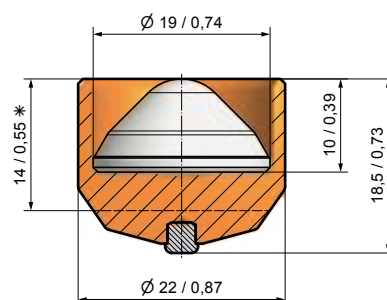

BTS08

BTSD22/18.5SG

100

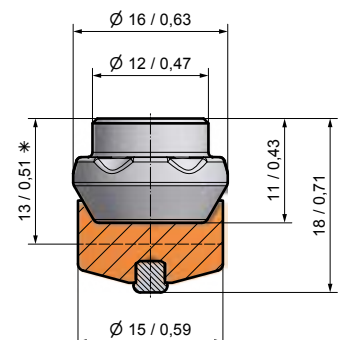

BTS10B

BTSD16/18B

150



US

GB

BETEK GmbH & Co. KG

Sulgener Str. 21 - 23
D-78733 Aichhalden
Germany

Service hotline + 49 (0) 74 22 / 5 65-440
Service fax line + 49 (0) 74 22 / 5 65-122

mining@betek.de
www.betek.de

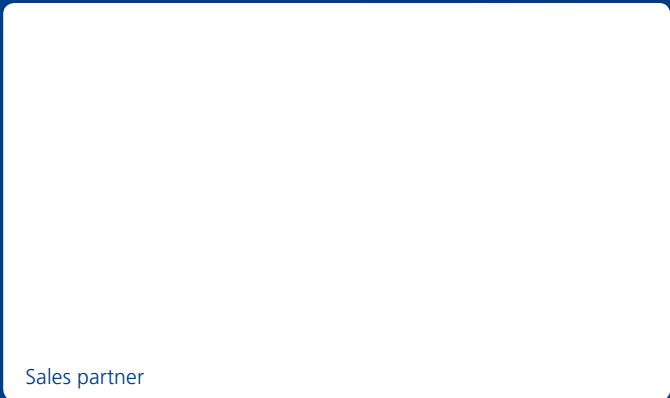

Sales partner

